

Type 2625 01i neo	Manual	solo [®] KLEINMOTOREN GMBH Stuttgarter Str. 41 D 71050 Sindelfingen, Germany
------------------------------------	---------------	-------------------------------------------------------------------------------------------------------

Table of Content

	page
Cover Page	1
Log of Revisions	1
Table of Content	2
1. General Engine Description	2
2. Technical Data	2
3. Operational Data and Limitations	3
4. Description of the ECU's Functions	3
5. Installing Instructions and Tightening Torques	3
6. Operating Instructions	5
7. Maintenance Instructions	6
8. Engine Problems: Troubleshooting, CAN-Messages, Fault Memory	7
9. Wiring and Fuel Supply	9
10. Power Curve	12

1. General Engine Description

- Twin - cylinder inline two - stroke engine
- Liquid cooling
- Lubrication by fuel-oil-mixture
- Electronic fuel injection
- Dual electronic high-voltage ignition
- Crankshaft layout for belt transmission
- Three-phase generator

2. Technical Data

Displacement	625 ccm	bore 76 mm	stroke 69 mm
Compression ratio	9,5 : 1		
Ignition system	Dual electronic high-voltage ignition, mapped		
Spark plugs	NGK B7HS, air gap at electrodes 0.7 mm		
Fuel injection	Electronic, two throttle-valves, mapped		
Sense of rotation	Clockwise in flight direction		
Fuel	Premium unleaded gasoline, min. 95 RON , AVGAS100LL, or mixtures of the two fuels		
Lubrication	Fuel oil mixture 1:50 (2%), above a density altitude of 6000ft: mixture 1:30 (3.3%) Oils according to the specification JASO FC or FD, recommended: SOLO two stroke oil		
Weight	24 kg without exhaust (aircraft manufacturer specific)		
Alternator	12 V 500 W		
Coolant	Antifreeze (Glystantin BASF G48) and tap water (0-20°dh) in a mixture of 40:60 (27°C)		

Type 2625 01i neo	Manual	 <small>KLEINMOTOREN GMBH Stuttgarter Str. 41 D 71050 Sindelfingen, Germany</small>
------------------------------------	---------------	-------------------------------------------------------------------------------------------------------------------------------------------------------------------------------------

3. Operational Data and Limitations

Takeoff	45 kW (61 hp) at a rotational speed of 6 250 rpm
Max. cont. power and rotational speed	45 kW (61 hp) at 6 250 rpm
Max. rotational speed	6 600 rpm, limited by the ECU
Idle rotational speed	approx. 2 300 rpm
Max. coolant temp.	115 °C (240°F) measured in the cylinder head
Fuel consumption	approx. 24,5 l/h at max. continuous power

4. Description of the ECU's Functions

- Based on air pressure, air temperature, throttle position and engine speed, the ECU calculates both the optimized injection quantity and the ignition timing.
- For safety reasons, the engine control system is equipped with the following duplex-redundant components: Engine speed sensor, throttle position sensor, injectors (channels A and B). These parts are monitored by the ECU. By recognition of a fault, it switches automatically over to the operative redundant component.
- The external Fuel Pumps Electronics Unit allows the ECU to monitor the fuel pumps as well.
- If an error is detected during engine operation, a code is sent to the engine monitoring device via CAN and stored in the ECU's fault memory.

5. Installing Instructions

- The cylinders have to be nearly vertical with cylinder heads on top when the engine is in its operating position.
- The engine can be mounted at the drive side flange with 4 bolts M8. At the cylinder heads are 4 more threads M8 and at the bottom of the crankcase are 4 threads M10.
- The load on the mounting threads may not exceed 5 kN each.
- If the propeller is driven by a belt, the static belt tension may not be higher than 5 000 N
- A water cooler with a cooling capability of 16 kW has to be used.
- If an electric starter is used, its power has to be at least 400 W.
- For the electrical wiring see the diagrams in chapter 9.
- By using the regulator SOLO GR 30 according to the wiring diagram (see ch. 9) the power supply of the engine components is redundant. Even if the battery fails the engine will continue to run.
- The ECU sends error codes via CAN if errors occur (see ch. 8.2). SOLO supplies the CAN protocol on demand.

Type 2625 01i neo	Manual	 <small>KLEINMOTOREN GMBH Stuttgarter Str. 41 D 71050 Sindelfingen, Germany</small>
------------------------------------	---------------	-------------------------------------------------------------------------------------------------------------------------------------------------------------------------------------

- *fuel system:*
 - Solo recommends to use the optional Fuel Supply Unit (BVE). It contains two pumps, the corresponding check-valves, the pressure regulator and a fine mesh filter. Instructions for installing the BVE:
 - Installation below the main tank, pumps horizontally and at the bottom.
 - The fuel line coming from the tank must be short and rising towards the fuel tank.
 - Dirt must be prevented from entering the main tank. Therefore, Solo recommends to use a tank inlet filter with a 10 micron mesh.
 - The pressure loss via the connection line to the engine (including fuel valve and fittings) may not exceed 50 mbar at a flow rate of 30 lph
 - If other fuel pumps are intended to be used, please contact Solo in advance and ask whether they are suitable. Especially pay attention to the following:
 - The fuel pressure in the fuel distributor of the throttle valve unit may not drop below 2,85 bar or rise above 3,1 bar during engine operation.
 - The injection valves must be protected by a 10 micron fine mesh filter.
 - If the current consumption is > 2A per pump, a larger smoothing capacitor may be required. (see page 10, Wiring Power Supply)
 - All fuel lines have to be protected against fire. Solo recommends Goodrich 811 fuel lines, size dash 04.

Type 2625 01i neo	Manual	 <small>KLEINMOTOREN GMBH Stuttgarter Str. 41 D 71050 Sindelfingen, Germany</small>
------------------------------------	---------------	-------------------------------------------------------------------------------------------------------------------------------------------------------------------------------------

Table of Torques

Spark plug	20 Nm
Drive pulley on crankshaft	100 Nm
Bolts and nuts M 6	12 Nm
Bolts and nuts M 8	20 Nm
Bolts and nuts M 10	40 Nm
Alternator rotor on crankshaft	80 Nm

Annotation: All tightening torques specified here are nominal values. The display deviation of the torque tools used must not exceed $\pm 5\%$.

6. Operating Instructions

A basic requirement for the safe operation of the engine is compliance with the following instructions:

- Check before startup:
- Check the fuel quantity in the tank.
 - Check throttle lever for free movement.
 - Check outside of engine, engine compartment, belt transmission and mountings for proper condition. Pay attention to leaks.
 - Ignition: „OFF“. Turn the propeller several times by hand to check for abnormal noise or hard motion of the engine.
 - Check the coolant level.
 - Check the error memory of the engine monitoring instrument.
- Startup:
- Throttle lever idle.
 - Open fuel cut-off valve.
 - Main switch „ON“.
 - Ignition "ON".
 - Check for safety space around the propeller. Engage the wheel brake.
 - Start the engine.
- Check before takeoff:
- Check the engine monitoring instrument for new error messages.
 - Conduct an ignition check at idle (2.300 RPM).
Maximum engine speed drop: 200 RPM.
- Takeoff and climb:
- Accelerate to full throttle because the injectors are monitored at full throttle only.
 - Limits of rotational speed and temperatures may not be exceeded.
- Stopping the engine: Switch off ignition. Further procedure according to aircraft manual.
- Startup during flight:
- Throttle lever idle.
 - Open the fuel cut-off valve.
 - Main switch „ON“.
 - Extend engine / propeller into flight position and disengage the propeller stop (according to the Aircraft's flight manual.)
 - Ignition "ON".
 - Push starter button until engine runs.
 - Throttle into full.

Type 2625 01i neo	Manual	 <small>KLEINMOTOREN GMBH Stuttgarter Str. 41 D 71050 Sindelfingen, Germany</small>
------------------------------------	---------------	-------------------------------------------------------------------------------------------------------------------------------------------------------------------------------------

7. Maintenance Instructions

In addition to the daily checks before startup and before takeoff, the following inspection and maintenance work is mandatory:

- | | |
|------------------------------------------------------------------------|------------------------------------------------------------------------------------------------------------------------------------------------------------------------------------------------------------------------------------------------------------------------------------------------------------------------------------------------------------------------------------------------------------------------------------------------------------------------------------------------------------------------------------------------------------------------------------------------------------------------------------------------------------------------------------------------------------------------------------------------------------|
| <p>Check every 25 hours or once a year (whatever is reached first)</p> | <ul style="list-style-type: none"> – General, thorough visual inspection: pay attention to loose or missing parts and leaks. – Check spark plugs. – Clean engine and air filter(s). – Put grease on the starter gearing. – Check all accessible screws and nuts for correct tightening torque. – Check all bowden cables and mechanical controls. – Check cables and electrical connections, especially the ECU power supply. To do this, temporarily pull the ECU fuse 1 and check if the ECU is still supplied with power. Repeat the same for the ECU fuse 2. – Turn the engine system's main switch temporarily off during a test run. The engine must continue running. |
| <p>Every 100 hours</p> | <p>Exchange the fuel filter integrated in the Solo Fuel Supply Unit.</p> |
| <p>Every 400 hours</p> | <ul style="list-style-type: none"> – Engine inspection and overhaul by Solo. – We strongly recommend a detailed check of the whole engine system wiring, including connectors. |
| <p>Conservation and storage of the engine.</p> | <p>If the engine is not used for more than 2 months, preserve and store it as follows:
 Inject approx. 2.5 ml of two stroke oil into each throttle body and crank the engine 10 turns by hand. Cover intake openings.</p> |

Type 2625 01i neo	Manual	 <small>KLEINMOTOREN GMBH Stuttgarter Str. 41 D 71050 Sindelfingen, Germany</small>
------------------------------------	---------------	-------------------------------------------------------------------------------------------------------------------------------------------------------------------------------------

8. Engine Problems

8.1 Troubleshooting

The engine doesn't start

1. Check battery voltage.
2. Check whether enough fuel is in the tank.
3. Check the ECU's power supply.
4. Ignition switch „OFF“! Turn the propeller by hand and check the engine's compression.
5. Check the electric starter. Does it turn the engine fast enough?
6. Check whether the engine is flooded with fuel. If so, pull the fuel pump fuses and try to start the engine with throttle half open, until you hear the first ignitions. Engage the fuel pump fuses again and start the engine.

The engine gets (too) hot

Warning! Overheating can cause severe damages! Shut off the engine as soon as possible! Check cooling system. Is the coolant level sufficient? Does the coolant pump work? Are any hoses squeezed? Is the radiator clogged?

The engine doesn't reach its nominal power or the rotational speed drops during operation

During flight, push – if possible – the throttle lever to full. (Only then the injectors are automatically monitored) If this doesn't help, stop the engine as soon as possible!

On the ground:

1. Check, whether the throttle valves open completely.
2. Ignition switch „OFF“! Turn the propeller by hand and check the engine's compression.
3. Conduct an ignition check at idle (2.300 RPM). Maximum engine speed drop: 200 RPM.
4. If not already done: Run the engine at least for 30 seconds with full throttle. Check the error memory of the engine monitoring instrument.
5. Clean or replace the air filter(s).

The alternator LED lights up, while the engine is running

Alternator or regulator are not working properly. Watch the Battery voltage!

Type 2625 01i neo	Manual	solo KLEINMOTOREN GMBH Stuttgarter Str. 41 D 71050 Sindelfingen, Germany
------------------------------------	---------------	------------------------------------------------------------------------------------------

8.2 CAN-Messages:

The ECU sends the following messages via the CAN bus:

CAN message	Cases in which a fault report is considered irrelevant :	recommended reaction in case of an error during flight:
TPS faulty (both channels)	Sensor faults are usually not critical, if they occur only rarely and for a few milliseconds. No reaction is required then. (Especially the occurrence of speed sensor errors during starting or stopping the engine is normal.)	Push the throttle lever to full or stop the engine.
engine temperature sensor faulty		No indication of engine temperature! It won't be noticed if the engine overheats.
internal air pressure sensor faulty/ air temperature sensor faulty		At low air density, the performance of the engine is weaker than normal.
TPS channel 1 faulty / TPS channel 2 faulty		No immediate action required.
speed sensor channel 1 faulty / speed sensor channel 2 faulty		The engine has an increased probability of failure. Fly carefully.
injection channel A defective / injection channel B defective		---
fuel pump 1 faulty / fuel pump 2 faulty	The tank is (almost) empty.	The engine has an increased probability of failure. Fly carefully.

Defects have to be corrected before the next flight.

8.3 Fault memory

The ECU stores all errors which are detected during engine operation in its internal fault memory. For reading this, the software WinTrijekt NEO is required. It can be downloaded from the Solo website: <https://aircraft.solo.global/gb/>.

9. Wiring and Fuel Supply

Wiring ECU

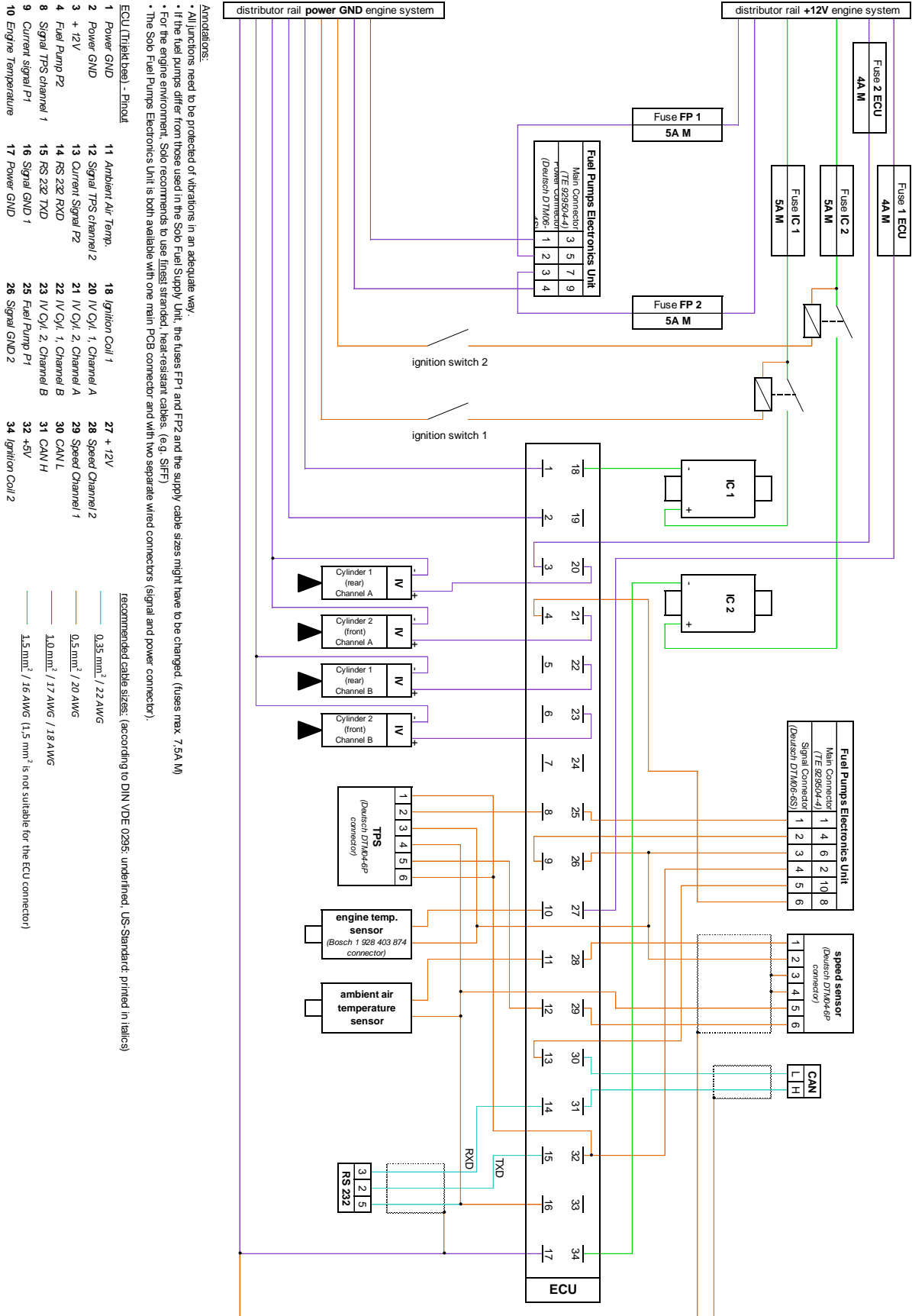

Wiring Power Supply

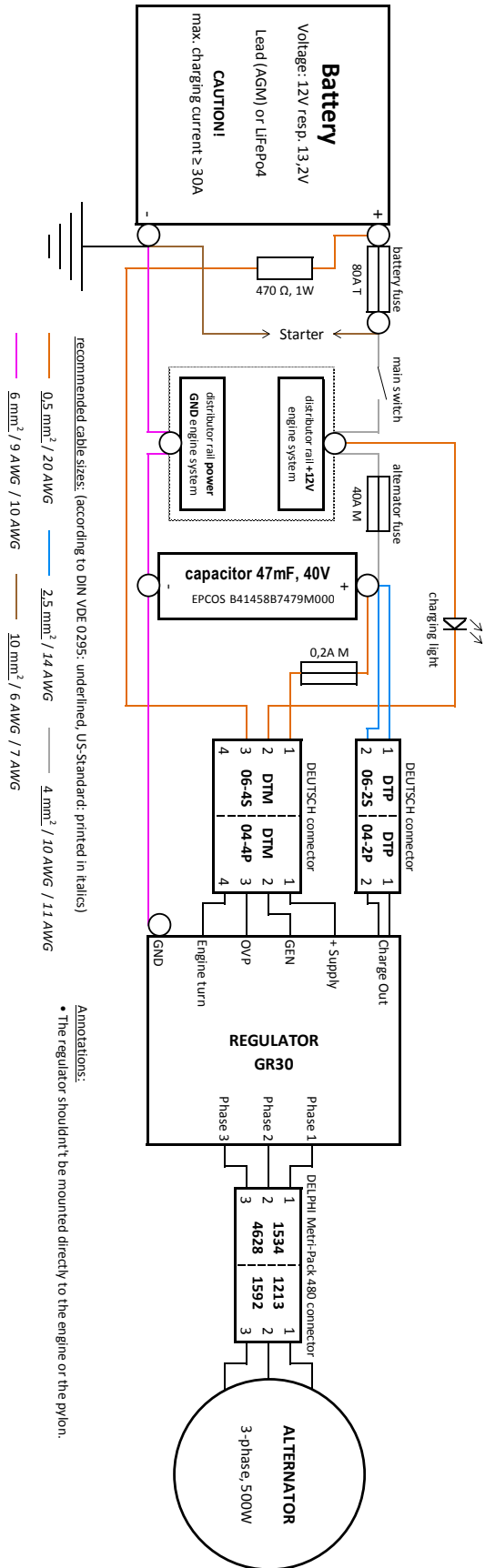

Connectors of the Fuel Pumps Electronics Unit

a) with Signal and Power Supply Connector

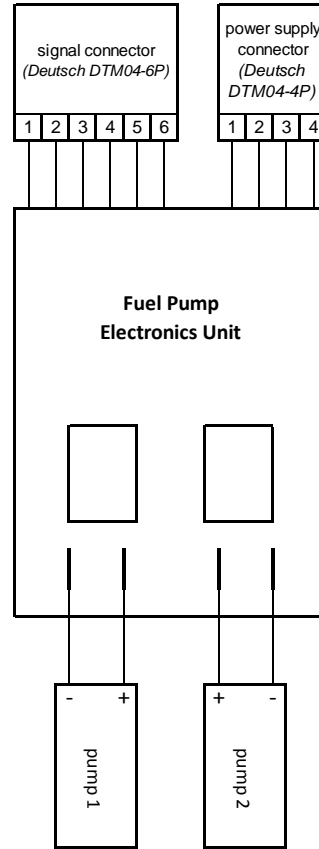

b) with Main Connector

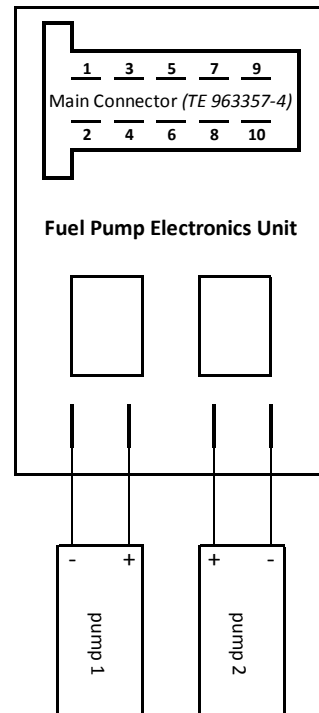

Fuel Supply

The following schematic shows the fuel system with the Solo Fuel Supply Unit (BVE) being used, but without the required tank inlet filter(s). If other pumps are installed, there may be deviations. These are within the aircraft manufacturer's area of responsibility then.

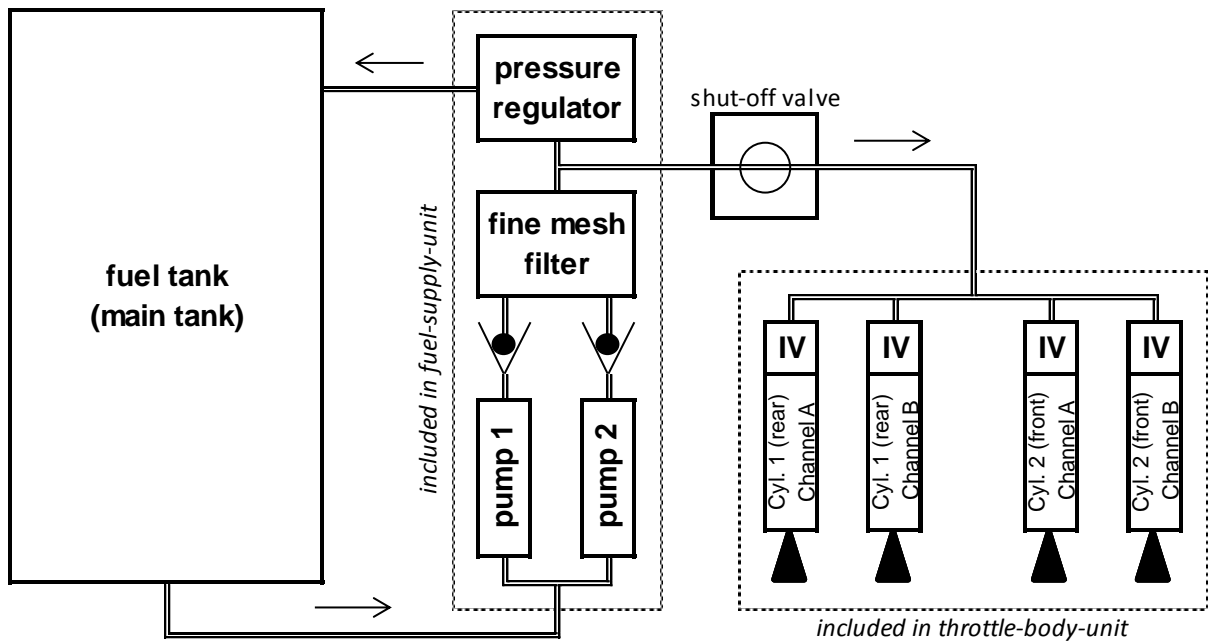

10. Power curve

