

# ***solo***

# ***service***

## **Service-manual**

For the aircraft engines

***solo 2 625 01i***

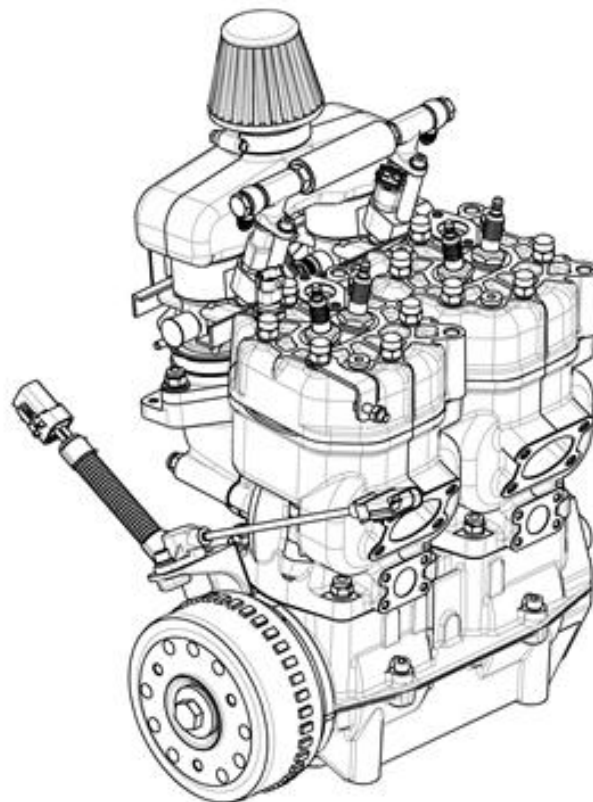

**solo** Kleinmotoren GmbH  
Stuttgarter Str. 41  
D 71069 Sindelfingen  
Tel.: (0049) 7031 - 3010  
Fax.: (0049) 7031 – 301231

Edition 2 dated December 4<sup>th</sup>, 2018

|                               |                       |                                       |
|-------------------------------|-----------------------|---------------------------------------|
| <b>Baureihe<br/>2 625 01i</b> | <b>Service Manual</b> | <b>SOLO<br/>KLEINMOTOREN<br/>GMBH</b> |
|-------------------------------|-----------------------|---------------------------------------|

## Table of contents

|       |  |    |
|-------|--|----|
| 1     | General hints and description of the engine .....            | 2  |
| 2     | Necessary tools .....  | 4  |
| 3     | Disassembly of the engine .....                              | 5  |
| 4     | Check of the individual parts .....                          | 6  |
| 4.1   | Cylinder heads.....  | 6  |
| 4.2   | Cylinders.....   | 6  |
| 4.3   | Piston and piston rings .....                                | 6  |
| 4.4   | Crankshaft .....   | 7  |
| 4.5   | Engine Control Unit (ECU).....                               | 8  |
| 4.5.1 | Wire diagram ECU 2625 01 i .....                             | 8  |
| 4.5.2 | Wire diagram redundancy system of the engine 2625 01 i ..... | 9  |
| 4.6   | Injection system .....                                       | 10 |
| 4.6.1 | Throttle body assembly 23 00 891 V3.....                     | 10 |
| 4.6.2 | Trouble shooting at the fuel injection system .....          | 11 |
| 5     | Assembly of the engine.....                                  | 13 |
| 6     | Notes.....   | 15 |

## 1 General hints and description of the engine

This service – manual shall give the engine specialist necessary hints for repairs and overhauls for the engine and help him solving specific problems. General knowledge of two-stroke-engines should be present.

This Service-manual is valid together with the engine-manual and the spare-parts-list.

### **! Attention!**

Because this engine is used as a certified engine for motor gliders the national authorizations of the specific certifying staffs must be maintained.

|                               |                       |                                       |
|-------------------------------|-----------------------|---------------------------------------|
| <b>Baureihe<br/>2 625 01i</b> | <b>Service Manual</b> | <b>SOLO<br/>KLEINMOTOREN<br/>GMBH</b> |
|-------------------------------|-----------------------|---------------------------------------|

## Description of the engine

The aircraft engine 2625 01i is based on the engine block of the engine 2625 01. The engine is a water-cooled two cylinder two-stroke engine with piston-ports. It has a displacement of 625 cm<sup>3</sup> with a stroke of 69 mm and a bore of 76 mm. It is lubricated by a fuel-oil mixture.

The engine 2625 01i, which can be converted according to the Service bulletin TM 4600 – 7 to the version with electronic fuel injection, the carburetor is replaced by an electronic fuel injection system into the manifolds, and also by an map-controlled ignition system. The former rotor and stator are replaced by an alternator, which supplies sufficient electric energy to operate the fuel injection and the ignition.

The take-off power is 45 kW by a speed of 6.200 RPM.

An ECU is controlling the injected amount of fuel and the ignition timing based on the engine speed, the position of the throttle valve, the engine temperature, the ambient pressure and the outside air temperature. This guarantees that the engine is running under optimal conditions.

In order to achieve maximum security in case of a breakdown of the ECU a simple redundancy system can optionally be installed, which supplies the engine by two additional injection valves. An ignition module which is driving the two coils of the engine is integrated in this system. The system is controlled by an additional RPM-sensor. Other sensors are not necessary.

The engine management system is consisting of the following components:

- Pre-filter, fuel pump, micro filter and fuel pressure regulator for the fuel supply. The fuel pressure in the system is regulated by the pressure regulator at 3 bars. The fuel line from the pressure regulator back to the fuel tank is pressure less.
- Engine Control Unit with ignition modules and a pressure sensor, which measures the atmospheric pressure. In the ECU the maps for fuel injection and ignition timing are stored. Based on the air pressure and the air temperature the ECU calculates the correct amount of injected fuel.
- The engine has 5 sensors. Facing the flywheel of the alternator there is an RPM sensor. At the throttle valve there is a sensor, which measures the opening of the shutter valve. At the rear cylinder head there is a temperature sensor measuring the coolant temperature. Near the air filters there is a sensor measuring the intake air temperature. In the ECU there is a pressure sensor measuring the atmospheric pressure.
- A double throttle valve assembly and one injection valve each, which are controlled by the ECU.
- Two double ignition coils with ignition wires leading to the front and rear cylinder each. The engine is running with minimal power loss fired by only one coil.

If a sensor fails or a wire breaks standard values are stored in the ECU which guarantee a limited operation of the engine. Only if the speed sensor fails the engine stops.

The ECU supplies constantly values about speed, temperatures and the condition of the sensors via a CAN-bus, which can be displayed to the pilot. In addition to that

|                               |                       |                                       |
|-------------------------------|-----------------------|---------------------------------------|
| <b>Baureihe<br/>2 625 01i</b> | <b>Service Manual</b> | <b>SOLO<br/>KLEINMOTOREN<br/>GMBH</b> |
|-------------------------------|-----------------------|---------------------------------------|

there is a failure memory, which can be read by the software Win trijekt. With this memory it can be detected, if one or more values have exceeded their limits. In addition to that the failure of a sensor can be detected. Short above the maximum engine speed the ignition is cut off. The starting of the engine must always be in idle position. A choke or other fuel enrichment systems are not necessary. The ECU has a serial interface, which allows the detection of the status of the ECU in operation. Special software is necessary for that. The settings and the access to delete the failure memory are protected by a password.

## 2 Necessary tools

In order to conduct an expert repair or check it is necessary to use functional tools in good condition. Except the usual tools, present in each engine workshop the following special tools are necessary.

| Pos. | SOLO order No. | Description   |
|------|----------------|---|
|      |                |   |
| 1    | 00 80 529      | Puller for hub  |
| 2    | 00 80 530      | Puller for Ignition flywheel  |
| 3    | 00 80 314      | Pressure tester   |
| 4    |                | Two stroke oil Castrol ACT>EVO, Castrol Super Two Stroke, Other oils with specification JASO FC or FD |
| 5    | 00 83 177      | Air filter oil  |
| 6    |                | Loctite 274   |
| 7    |                | Loctite 270   |
| 8    |                | Loctite 574   |
| 9    |                | Loctite 243   |
| 10   |                | Loctite 638   |

### 3 Disassembly of the engine

| Pos. | Operation  | Tools, aid                                       |
|------|--|--|
| 1    | Clean engine before disassembly  | Use fuel   |
| 2    | Disassemble the throttle system from the manifolds   | Open end wrench 13 mm                            |
| 3    | Disassemble muffler, clean muffler from debris and coal.   | Allen key 6 mm                                   |
| 4    | Loosen flywheel of the generator and pull off flywheel with suitable puller.   | Puller SOLO-No. 00 80 530                        |
| 5    | Disassemble the stator of the generator completely.  |  |
| 6    | Loosen hub at the front end of the crankshaft and pull off with the suitable puller.   | Socket wrench 19 mm<br>Puller SOLO No. 00 80 529 |
| 7    | Loosen nuts at the cylinder head.  | Socket wrench 13 mm                              |
| 8    | Lift cylinder head.  |  |
| 9    | Mark cylinder head, cylinder and piston for matching.  |  |
| 10   | Loosen nuts at the bottom of the cylinder and lift cylinder carefully.   | Open end spanner 12 mm                           |
| 11   | Disassemble the piston-pin lock carefully. Push piston-pin out of the piston by hand.  |  |
| 12   | Loosen the 4 bolts on the side of the crankcase and move the two halves of the crankcase apart carefully so that they don't get out of line. Clean both parts.<br><b>ATTENTION! ON ENGINES WITH DOUBLE BEARING ON THE DRIVE SIDE LOOSEN THE FOUR BOLTS AT THE FRONT-END FIRST.</b> |  |
| 13   | Take off seals, locks and outer rings of the roller bearings by hand.  |  |

## 4 Check of the individual parts

### 4.1 Cylinder heads

- Clean the inside part of the cylinder head from coal. Fuel can dissolve rests of burnt oil. Heavy oil-carbon deposit can be removed with a steel brush.
- Check both threads for the spark-plugs if damaged
- Clean the sealing surface.

### 4.2 Cylinders

- Check the cylinder surface (Coating) visually if there are damages (Scratches).
- Check the diameter of the cylinder in direction of the crankshaft and rectangular:

| Dimension          | New             | Wear limit |
|--------------------|-----------------|------------|
| 10 mm below top    | 76 mm +/- 0,005 | 76,01 mm   |
| 30 mm below top    | 76,mm +/- 0,005 | 76,01 mm   |
| 25 mm above bottom | 76 mm +0,01     | 76,02 mm   |

- Check visually the grooves for the o-rings at the top of the cylinder.
- Check the entire cylinder for cracks or damages of the sealing surfaces.
- Remove oil-carbon deposit on the coating and in the exhaust port.

### 4.3 Piston and piston rings

- Remove oil-carbon deposit on the piston top carefully.
- Check piston diameter. Measure the diameter rectangular to the piston pin boss.

| Dimension                | New            | Wear limit |
|--------------------------|----------------|------------|
| D1=DN 22 mm above bottom | 76 mm +/- 0,06 | 75,9 mm    |
| D2: 59,5 mm above bottom | 76 mm +/- 0,08 | 75,8 mm    |
| D3: 69 mm above bottom   | 76 mm - 0,093  | 75,7 mm    |

- Check vertical play of the piston rings  
New 0,05 mm - 0,10 mm      wear limit 0,20 mm
- Check wear of the piston rings.  
Distance between the two ends if the piston ring is mounted into the cylinder:  
New 0,2 - 0,35 mm      wear limit 0,8 mm  
No light has to be seen between cylinder wall and piston ring if the cylinder is held against a lamp.

|                               |                       |                                       |
|-------------------------------|-----------------------|---------------------------------------|
| <b>Baureihe<br/>2 625 01i</b> | <b>Service Manual</b> | <b>SOLO<br/>KLEINMOTOREN<br/>GMBH</b> |
|-------------------------------|-----------------------|---------------------------------------|

#### **4.4 Crankshaft**

The Crankshaft can be disassembled only by the manufacturer.

The main bearings at the drive side or the ignition side (roller bearings) can be replaced. To conduct this, the inner rings must be grinded carefully on one spot until only 0.3 mm of wall thickness is left. Then they can be cracked by using a chisel. After that they can be slipped off the shaft.

- Check true running on a centering device. The eccentricity at the bearings should not exceed 0.04 mm. If the eccentricity is more the crankshaft can be adjusted by the manufacturer.
- Check axial play at the con-rod bearings. The play must be between 0.35 und 0.5 mm.

### 4.5 Engine Control Unit (ECU)

The following wire diagram shows the connection between the ECU and the various components of the engine. The functions of the ECU where described in chapter 1. The wire diagram of the redundancy system is shown below.

#### 4.5.1 Wire diagram ECU 2625 01 i

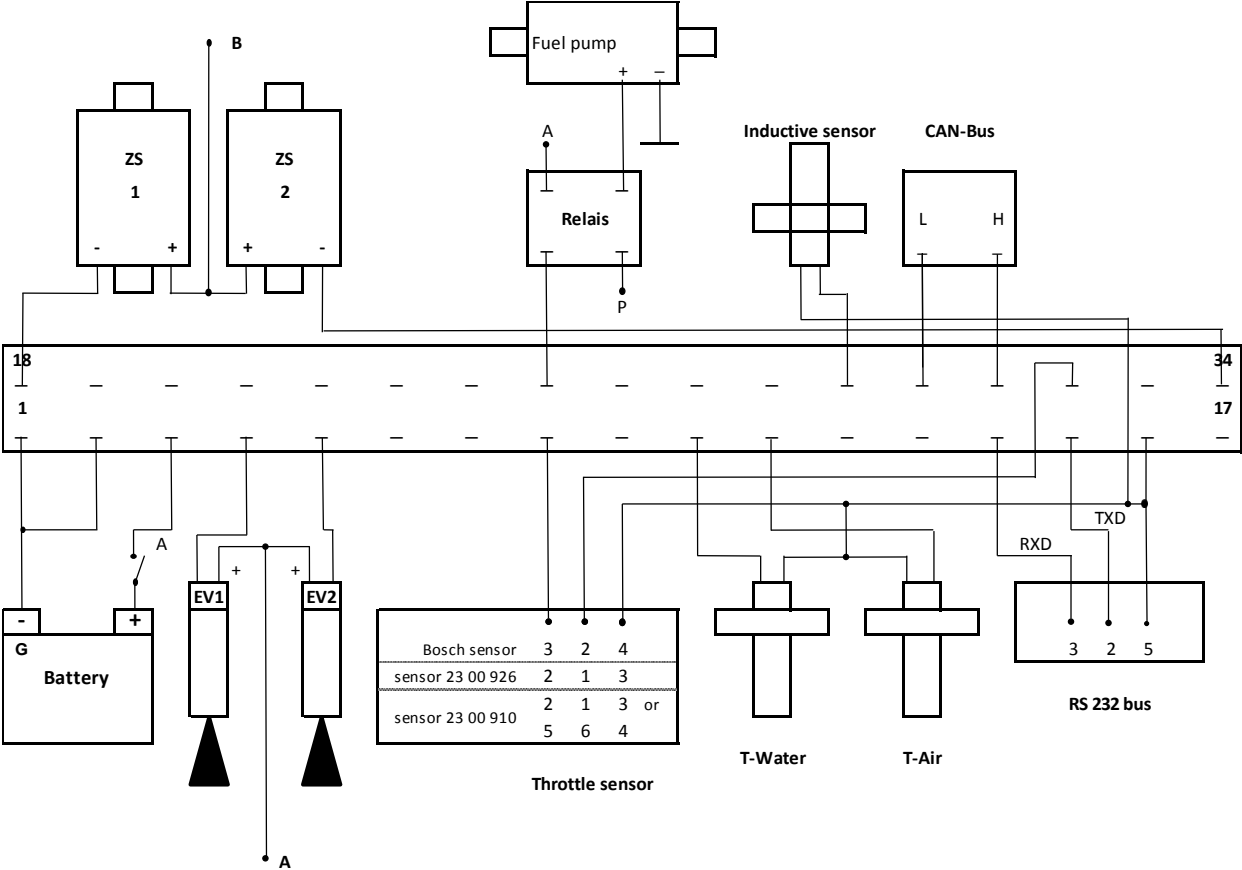

G = Ground  
A = Power Engine System (Fuse 5A)  
B = Power Ignition (Fuse 10A)  
P = Power Fuel pump (Fuse 15A)

Plug connection ECU

|       |                                     |    |                       |
|-------|-------------------------------------|----|-----------------------|
| 1 & 2 | Power Ground                        | 18 | Ignition coil 1       |
| 3     | Power Engine System                 | 34 | Ignition cCoil 2      |
| 4     | Injection Valve 1 (Alternator side) | 25 | Relay Fuel Pump       |
| 5     | Injection Valve 2 (Drive side)      | 29 | RPM Transducer        |
| 8     | Signal Throttle Valve Transducer    | 16 | Ground RPM Transducer |
| 32    | Power 5V Throttle Valve Transducer  | 30 | CAN-Bus (CANL)        |
| 16    | Ground Sensors                      | 31 | CAN-Bus (CANH)        |
| 10    | Signal Water Temperature Sensor     |    |                       |
| 11    | Signal Air Temperature Transducer   |    |                       |
| 14    | Computer Interface RXD              |    |                       |
| 15    | Computer Interface TXD              |    |                       |
| 16    | Computer Interface Ground           |    |                       |



**4.5.2 Wire diagram redundancy system of the engine 2625 01 i**

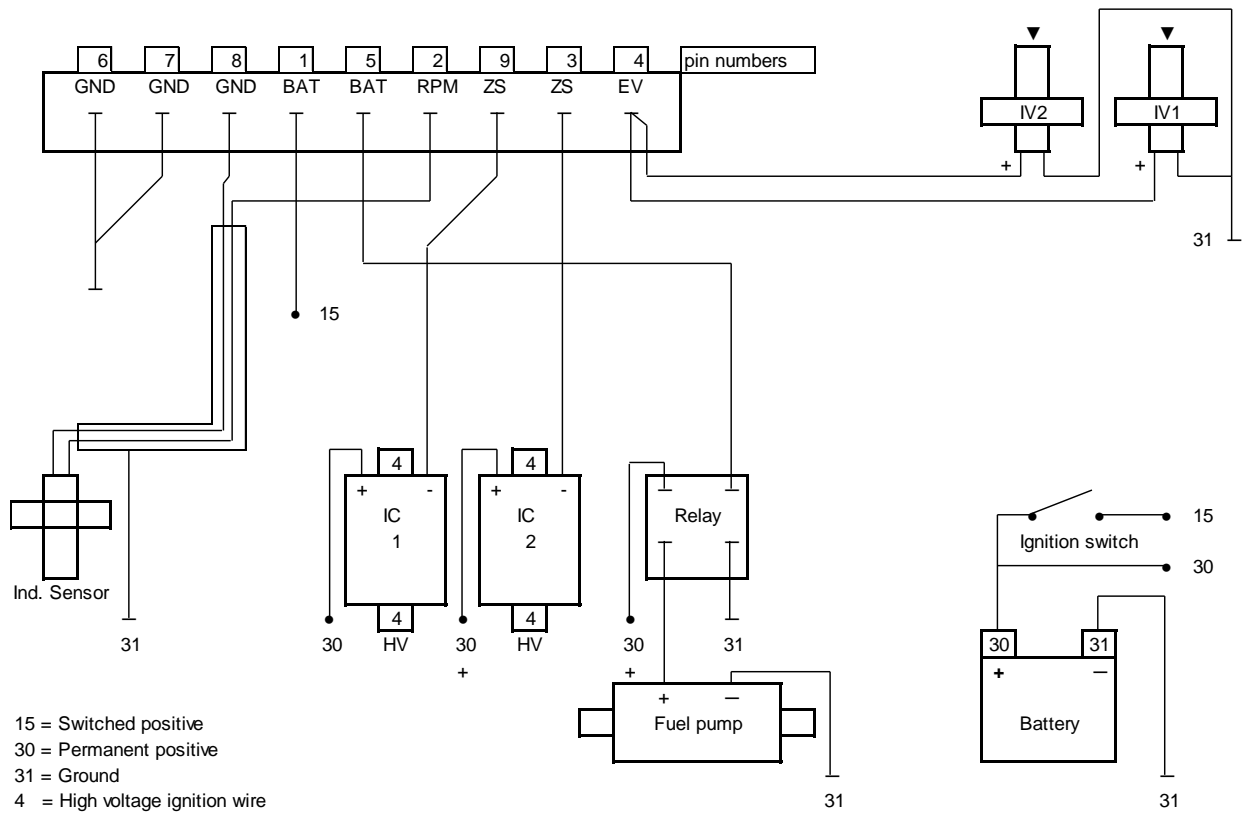

**Plug connection Redundancy System**

- BAT :Switched positive
- BAT :Switched positive
  
- GND :Ground
- GND :Ground
  
- EV :Injection valve 1 and 2
  
- ZS :Ignition coil
- ZS :Ignition coil
  
- RPM :RPM sensor
- GND :Ground RPM sensor

## 4.6 Injection system

### 4.6.1 Throttle body assembly 23 00 891 V3

#### a) Notes on disassembling

- The throttle-valve-screws (00 18 481) are caulked and need to be removed by drilling.
- The bush 20 42 790 is best removed by an M12 tap by hand. However, it will be damaged and needs to be replaced.



#### b) Inspection of the individual parts:

Clean all parts and check them for wear, corrosion, cracks and other damages.

Replace poor parts.

Wear limits:

- 1) shaft bearings: bearing bushings (00 50 262 and 00 50 261): 8,1mm,  
shaft (22 00 800): 7,92mm
- 2) spring wire holes in the spring holders (20 42 786 and 20 42 787): 1,55mm

#### c) Assembling

- Aligning of the parts

|   |  |
|---|--|
| <p>The two sheet metal parts (20 31 127 and 23 00 906) should be flush at the front and rear.</p>                   |  |
| <p>The fuel distributor must fit tightly to the flaps of the injector-side metal sheet.</p>                         |  |
| <p>The axial clearance of the throttle shaft must be between 0,05 and 0,1 mm at room temperature.</p>               |  |
| <p>Areas of the same color must be in the same plane.</p>   |  |
| <p>The distance between the fuel distributor and the throttle bodies must be <math>26,6 \pm 0,1</math> mm each.</p> |  |
| <p>The throttle valves must not touch or rub against the throttle bodies when fully closed.</p>                     |  |

|                               |                       |                                       |
|-------------------------------|-----------------------|---------------------------------------|
| <b>Baureihe<br/>2 625 01i</b> | <b>Service Manual</b> | <b>SOLO<br/>KLEINMOTOREN<br/>GMBH</b> |
|-------------------------------|-----------------------|---------------------------------------|

*Annotation:* The holes in the sheet metal parts may be drilled if necessary:  
through-holes for M4 screws: max. 4.9mm,  
through-holes for M5 screws: max. 5,8mm.

- thread lockage:
  - > All M4 / M5 screws and the plug screws must be secured with Loctite 243.
  - > The throttle-valve-screws (00 18 481) must be caulked.
- tightening torques:
  - > screws M4: 3,5Nm;  
exception: mounting screws of the throttle position sensor: 1,8Nm
  - > all screws M5: 6,5Nm, plug screws: 12Nm
  - > throttle-valve-screws: by hand
- Throttle position sensor (TPS): The TPS must be aligned so that the signal voltage output in the WinTrijekt status window is  $4.56 \pm 0.08$  V.

## 4.6.2 Trouble shooting at the fuel injection system

### 4.6.2.1 Engine does not start

|                              |  |
|------------------------------|--|
| No fuel                      | Check the fuel lines and the function of the fuel pump.        |
| No spark at both spark plugs | Weak battery, charge the battery.<br>Broken wire               |
| No spark at one spark plug   | Spark plug defect. Ignition coil defect. Ignition wire broken. |

### 4.6.2.2 Failures during operation

|                                  |  |
|----------------------------------|--|
| Engine overheats                 | Not enough coolant. Water pump defect. Fuel pressure not sufficient.   |
| Engine does not reach full power | Fuel pressure not sufficient. Fuel filter clogged. Throttle valve does not open completely. Spark plugs defect.<br>Fuel pump defect. |

### 4.6.2.3 Failure memory

The ECU has a failure memory, which detects failures at the system and stores them. With the software Win trijekt you can read the memory but not delete.

### 4.6.2.4 Software for the ECU

On the page <https://aircraft.solo.global/de/2625-01i/17-solo-flugmotor-2625-01-i.html> software (Win trijekt) can be downloaded, which allows to connect a computer to the serial interface of the ECU. After installing the software, the status of the ECU can be checked. Connect the serial cable to the computer and the ECU and start the software. Then switch the ignition (ECU) to "ON". If the software shows „connected“the status of the sensors and the ECU can be checked.

The status window shows the status of the sensors, the injection time and the ignition angle during engine operation.

| status                              |          |                                      |                |
|-------------------------------------|----------|--------------------------------------|----------------|
| rotation speed                      | 3017 rpm | lambda                               | 1 0.70 V       |
| injection time                      | 6578 µs  | throttle pot.                        | 9 deg 0.90 V   |
|                                     | 33.0 %   | air mass sensor                      | 508 ‰ 2.49 V   |
| ignition angle                      | 22 deg   | battery voltage                      | 12.24 Volt     |
| idle controller                     | 2 %      | engine temperature                   | 88 °C 0.76 V   |
| pressure load                       | 42 %     | air temperature                      | -3 °C 0.91 V   |
| no. of rev. errors                  | 3/0      | air pressure (int.)                  | 978 hPa 3.93 V |
| consumption                         | 20.3 l/h | air pressure (ext.)                  | 983 hPa 3.00 V |
|                                     |          | temperature (int.)                   | 28.4 °C 4.49 V |
| <b>calc. of injection time (µs)</b> |          | <b>calc. of ignition angle (deg)</b> |                |
| air mass                            | 5602     | ignition angle (from table)          | 22             |
| correction                          | 0        | air temperature                      | 0              |
| base time                           | 5602     | air pressure (ext.)                  | 0              |
| engine temperature                  | 24       | engine temperature                   | 0              |
| lambda control                      | 0        | acceleration                         | 0              |
| function input                      | 0        | ignition angle                       | 22             |
| acceleration                        | 0        |                                      |                |
| switch time                         | 953      |                                      |                |
| injection time                      | 6578     | field changing                       |                |

Check the following indications:

**No. of rev. errors:**

If the number of rev. Errors increases during starting or engine operation, a failure of the speed sensor can be indicated. Check sensor and wires.

**Throttle potentiometer**

In idle position the value should be around 10 degrees and during full throttle 90 degrees. With other readings the sensor is defect.

**Engine temperature**

Check the engine temperature with a second gauge if it is plausible.

**Air temperature**

Check the air temperature with a second gauge if it is plausible.

**Air pressure (int.)**

This value can be checked with an altimeter.

Other sensors are not connected.

## 5 Assembly of the engine

Before assembly apply two-stroke oil on crankshaft bearings, pistons and piston pins.

| <b>Operation</b>  | <b>Tool, aid</b>                           |
|---|--|
| 1<br>Heat inner rings of roller bearings up to 180°C<br>And slip on free ends of the crankshaft. The flange of these rings has to be next to the crank web.<br>Attention! For engines with double bearing first slip on the ring with flange, then the spacer ring and then the ring without flange. All three rings must be positioned next to each other.                   | Heating plate with temperature control     |
| 2<br>Clean crankcase with thinner. Remove possible rests of former gaskets completely.  |  |
| 3<br>Apply Loctite 574 on contact surfaces of the crankcase halves and put crankshaft into the lower half. Before that apply two-stroke oil on all bearings. Assemble all rings and seals together with the crankshaft.   | Loctite 574<br>Two-stroke oil              |
| 4<br>Mount other half of the crankcase plus the 4 bolts on both sides with Loctite and tighten with a torque wrench.<br>Attention! On engines with double bearings mount the steel liner with the two lower bolts first. Then tighten the four bolts on the sides of the crankcase. Then tighten the 4 bolts on the front of the steel liner. Apply Loctite 274 on all bolts. | Torque wrench (12 Nm)<br>Loctite 274       |
| 5<br>Assemble piston with rings to the connecting rod and secure with piston-pin locks. Push piston pin into piston by hand. Apply two-stroke oil on all parts.   | Piston ring clamp bent out of spring steel |
| 6<br>Mount cylinders and mount nuts M8 so that the cylinders are still movable.   |  |
| 7<br>Assemble exhaust manifold with gaskets in order to get cylinders in line. Then tighten the 4 nuts on each cylinder.  | Torque wrench<br>(20 Nm)                   |
| 8<br>Assemble cylinder heads  | Torque wrench (20 Nm)                      |
| 9<br>Plug all openings (Intake and exhaust ports) with steel parts and rubber parts in the shape of the flanges. Check if the engine block is sealed with 0.5 bar pressure. Pressure loss should not exceed 0.1 bars per minute.  | Pressure tester                            |

|                               |                       |                                       |
|-------------------------------|-----------------------|---------------------------------------|
| <b>Baureihe<br/>2 625 01i</b> | <b>Service Manual</b> | <b>SOLO<br/>KLEINMOTOREN<br/>GMBH</b> |
|-------------------------------|-----------------------|---------------------------------------|

|    |   |                                      |
|----|---|--------------------------------------|
| 10 | Assemble stator of the generator. Secure all bolts with Loctite.                        | Torque wrench (12 Nm)<br>Loctite 270 |
| 11 | Assemble flywheel. Clean cone and flywheel with thinner first.                          | Torque wrench (80 Nm)                |
| 12 | Assemble throttle system on intake manifolds.   |                                      |
| 13 | Assemble air filter.  |                                      |
| 14 | Check sealing of the cooling system with a pressure of 1 bar. No pressure loss allowed. | Pressure tester                      |

|                               |                       |                                       |
|-------------------------------|-----------------------|---------------------------------------|
| <b>Baureihe<br/>2 625 01i</b> | <b>Service Manual</b> | <b>SOLO<br/>KLEINMOTOREN<br/>GMBH</b> |
|-------------------------------|-----------------------|---------------------------------------|

## **6 Notes**