

**solo**

KLEINMOTOREN GMBH

Postfach 60 01 52 , D 71050 Sindelfingen

# Manual for Engine 2625 02

## Manual

for the

### Engine SOLO type 2625 02

Serial - no. ....  
 Manufactured .....

Aircraft - type .....  
 Registration no. ....  
 Owner .....

#### Log of revisions

no.	edition date	revised page no.	date of entry
1	Oktober 3 <sup>rd</sup> , 1999	2	Oktober 3 <sup>rd</sup> , 1999
2	January 5 <sup>th</sup> , 2001	1	January 5 <sup>th</sup> , 2001

edition 1 September 24th, 1997	revised edition	page no. 0
-----------------------------------	-----------------	------------

**Table of contents****page**

Cover page	0
Log of revisions	0
Table of contents	1
1. General engine description	1
2. Technical data	1
3. Operational data and limitations	2
4. Installing Instructions	2
5. Operating instructions	3
6. Maintenance instructions	4
7. Trouble shooting	4
8. Wiring diagram	5
9. Power sheet	5

**1. General engine description**

- Twin - cylinder in line - two - stroke - engine
- Liquid cooling
- Lubrication by fuel-oil-mixture
- Two diaphragm carburetors
- Dual electronic high-voltage ignition
- Crankshaft layout for belt transmission
- Electric starter
- AC generator

**2. Technical data**

Displacement	625 cm <sup>3</sup>	bore 76 mm	stroke 69 mm
Compression ratio	9,5 : 1		
Ignition unit	Dual electronic high-voltage ignition (Ducati Energia)		
Spark plugs	BOSCH W5 AC, gap at electrodes 0.5 mm		
Carburetor	Mikuni diaphragm carburetor Typ BN 38		
Sence of rotation	Clockwise in flight direction		
Fuel	Premium unleaded Min. 95 RON , AVGAS100LL		
Lubrication	Fuel oil mixture 1:50 (2%),CASTROL Super TT oder TTS For USA SOLO Two Stroke oil (SOLO Inc. Newport News VA)		
Dry weight	24 kg		
Generator	12 V	150 W	

### 3. Operational data and limitations

Take-off-speed,power      6 500 rpm with a power of 47 kW (64 hp)  
 Max. cont. speed, power    6 500 rpm with a power of 47 kW (64 hp) /  
 Max. rpm                      7 000 rpm

Idle rpm                        approx .2 500 rpm  
 Max. temp. cooling liquid    115 °C (240°F) measured in the cylinder - head  
 Fuel consumption              Max. continous power approx. 24,5 l/h

### 4. Installing Instructions

Installing Instructions      The engine can be mounted at the driveside flange with 4 bolts M8. At the cylinder heads there are 4 more threads M8 and at the bottom of the crankcase there are 4 threads M10. The cylinders have to be in vertical position when the engine is its operating position.

The load on the mounting threads can be 5 kN each.

The fuel line has to be protected against fire.

A fuel pump with a fuel pressure of min.0,2 bar and a maximum pressure of 0,4 bar is to be used.

A fuel filter with 6 to 7 µm has to be installed in the fuel line.

A watercooler with a cooling capability of 14 kW has to be used.

If an electric starter is used, its power has to be at least 400 W.

If an electric starter is used, its power has to be at least 400 W.

If the propeller is driven by a belt the belt tension may not be higher than 2 000 N at engines up to No. 19. If the belt tension must be higher, the use of an additional bearing is necessary.

At higher engine-numbers (from 20) the belt tension can be 2 500 N max.

Table of torques	Spark plug	20 Nm
	Drive pully on crankshaft	100 Nm
	Bolts and nuts M 6	12 Nm
	Bolts and nuts M 8	20 Nm
	Bolts and nuts M 10	40 Nm
	Magneto on crankshaft	80 Nm

## 5. Operating instructions

For correct function of the engine it is absolutely necessary to follow exactly the following operating and maintenance instructions.

Before starting the engine	Has daily check been made? Open throttle lever fully. Check throttle lever for free movement on full range. Ignition:"OFF". Turn propeller several times by hand to check for abnormal noise or hard motion of the engine.
Starting the engine	Main switch on. Open fuel cock. Fuel pump "ON". Ignition "ON". Check for safety around the propeller. Engage the wheel brake. Disengage the propeller brake. Start the engine and set the throttle lever until the engine runs smoothly.
Take off	Switch off both ignition circuits.at approx. $3\ 500\ \text{Min}^{-1}$ .Maximum rpm - drop $300\ \text{Min}^{-1}$ . Accelerate to full throttle. Limits of rpm - level and temperatures may not bee exceeded.
Stopping the engine	Before stopping the engine, run it for approx. 1 minute at 20% of throttle setting. Switch off ignition and close the fuel cock.
Starting the engine in flight	Move the engine into flight position. Disengage the propeller stop. Throttle in idle position. Fuel cock open. Fuel pump on. Ignition on. Start until engine runs. Throttle into full.

## 6. Maintenance instructions

Daily check before flight	Check fuel quantity. Check throttle lever for free movement. Check outside of engine, engine compartment, belt transmission and mountings for proper condition. Check cooling liquid.
Inspection after 25 hours of operation or after 1 year.	Replace spark plug. Check entire engine for loose parts and bolts. Check all bowden cables and controls. Check wires and electrical connections. Check belt tension. Put grease on starter gears.
Inspection after 400 hours of operation. Conservation and storage of the engine.	Inspection by the manufacturer.  If the engine is stored for more than 2 months or is out of use, preserve and store it as follows: Drain fuel tank. Inject approx. 2.5 ml of two stroke oil into each carburetor and crank the engine 10 turns by hand. Cover intake openings on carburetors and exhaust tube on muffler.

## 7. Trouble shooting

### Engine does not start

No fuel supply	Check fuel line to carburetors. Check function of fuel pump.
Carburetors are not sealed	Open cover of carburetor and clean fuel valve.
No spark on both spark plugs of ignition circuit	Too low cranking rpm because of weak battery. Defective wires or ignition box defective.
No spark on one spark plug of ignition circuit	Defective spark plug. Defective wires or ignition box..

### Engine does not run properly

Engine gets too hot	Colling liquid level low. Lean setting because of dirt in the carburetor. Fuel supply not sufficient.
Engine does not reach full rpm	Fuel supply not sufficient. Fuel filter clogged. Throttle does not open completely. Defective fuel pump. Defective spark plugs.

## 8. Wiring diagram

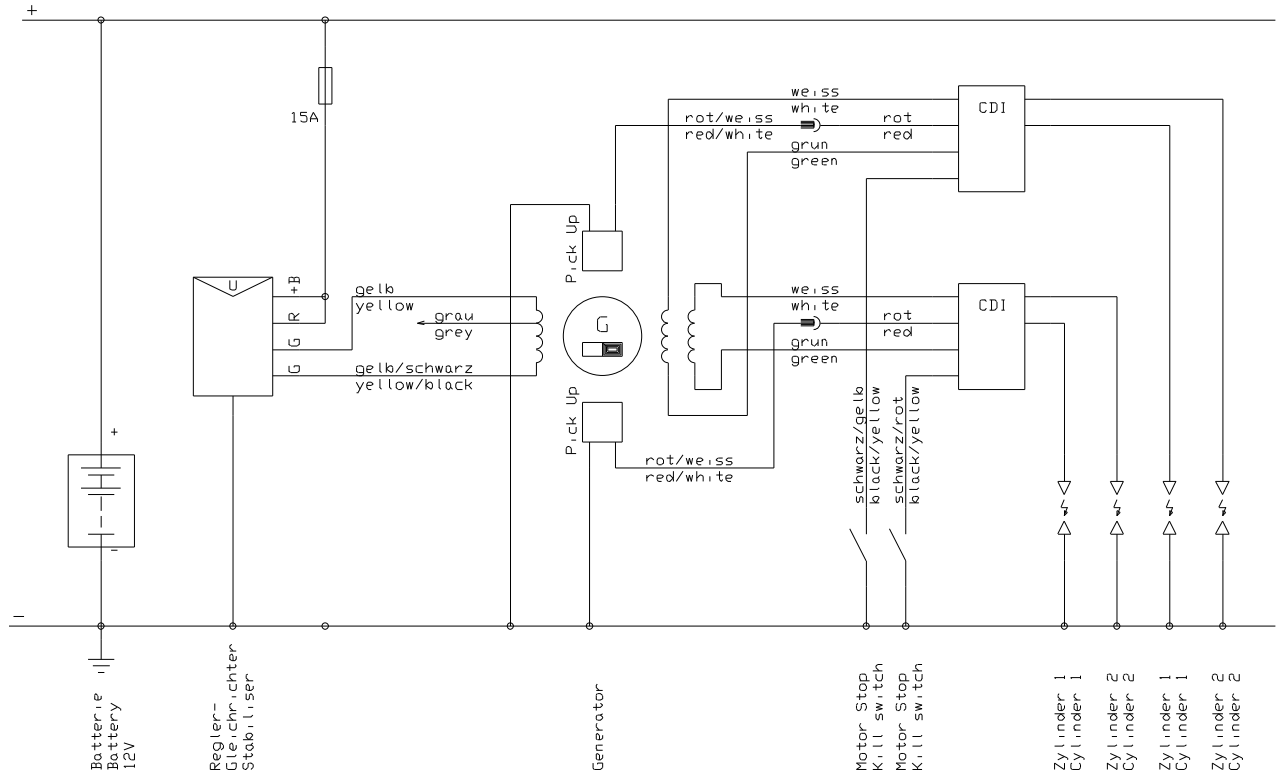

## 9. Power sheet

